

## 1. Introduction

### Problem:

- In the future robots will be expected to operate over large geographical areas
- Storing maps of entire environment is inefficient and impractical

### Idea:

- Use small maps around areas of interest (landmarks)
- Store commands to move between landmarks
- Encode those commands using the extended Motion Description Language (MDLe)

## 2. MDLe and Kinetic State Machines (KSM)

- MDLe: A language for hybrid motion control
  - Compose interrupt-driven control laws from a set of simple primitives and syntactic rules
- Kinetic State Machine
  - Robot modeled by differential equation
  - Outfitted with set of sensors and actuators
  - Has access to set of timers

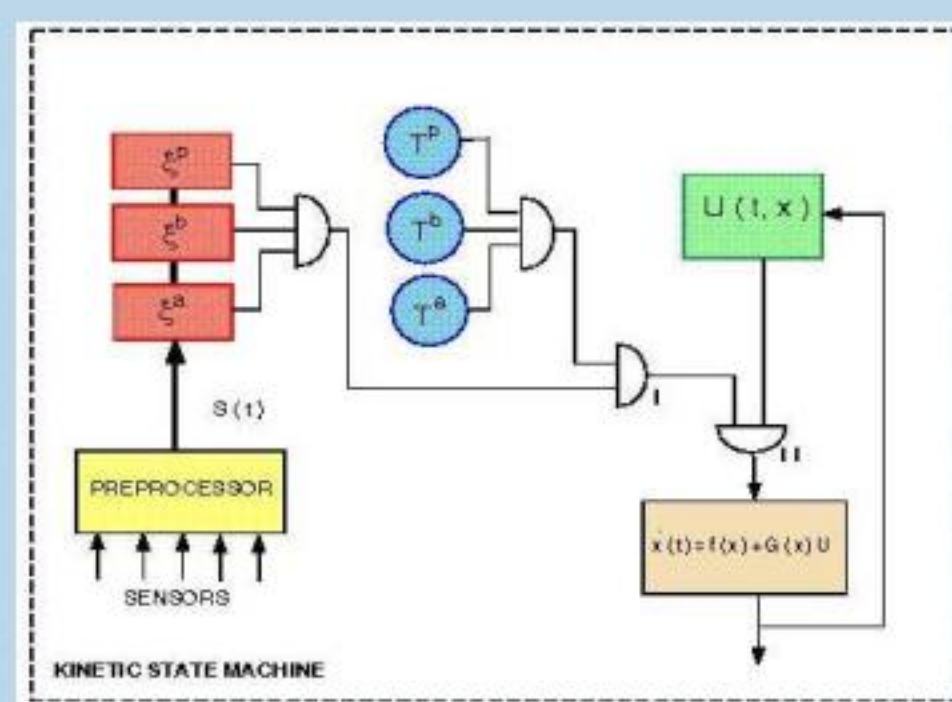

## 4. Landmarks and maps

- A landmark is a terrain feature or set of features by which a robot can determine it has arrived a place
- Each landmark has its own coordinate system
- Once on a landmark map existing map-based planning can be done for navigation
- Different landmarks can use different types of maps depending on what is most useful
- Current implementation uses the evidence grid approach developed by H. Moravec

## 5. Connecting Landmarks with MDLe: The Graph

- MDLe plans provide information encoded in feedback control laws
- Replace detailed information about intervening terrain and relative geographic information with a plan
- Allows efficient representation of large areas by only storing local information around regions of interest

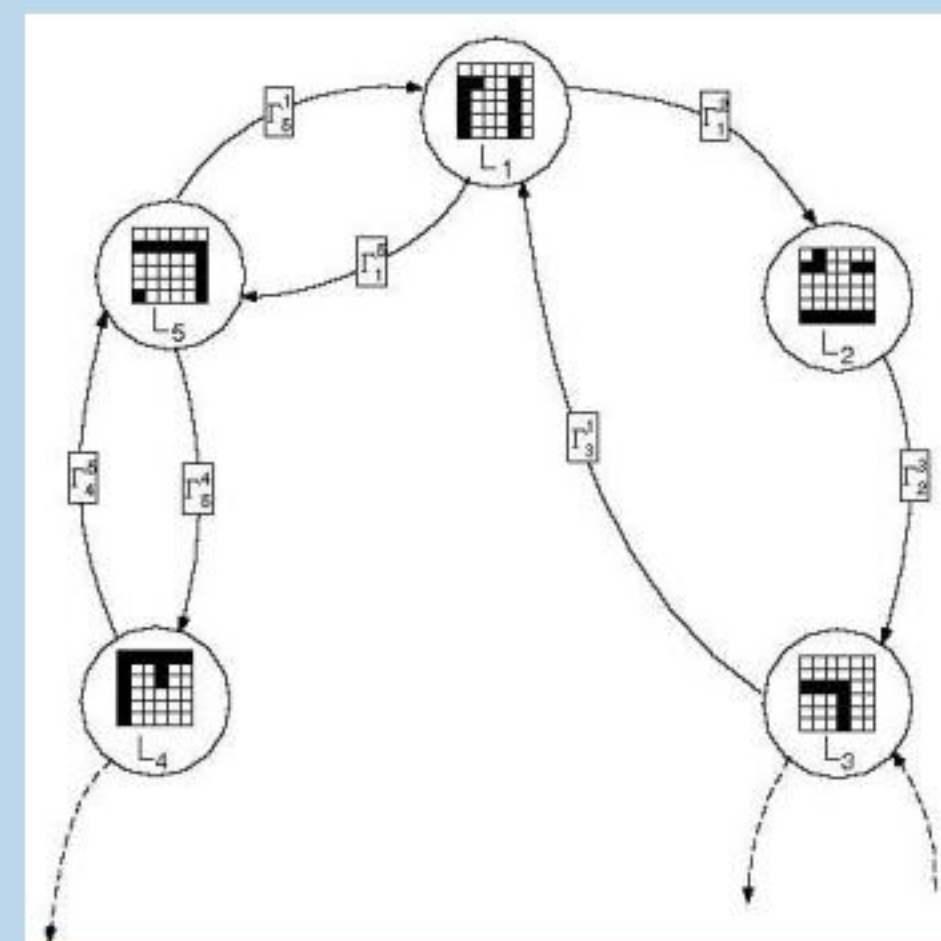

## 6. Experimental results

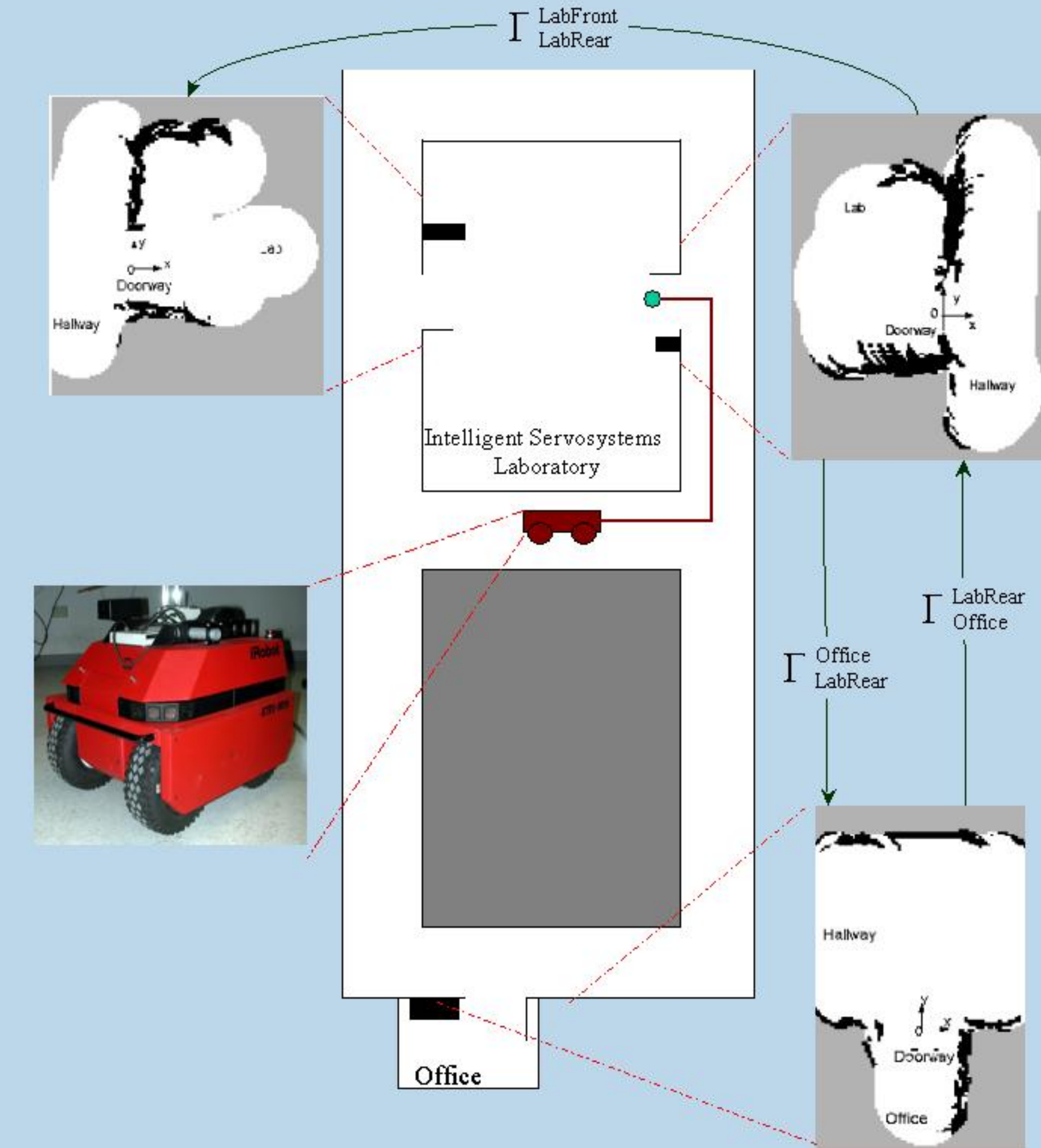

## 7. Future work

- Localization on a graph
- Automatic generation of a graph representation
- Automatic generation of connecting plans

### References:

- V. Manikonda, P.S. Krishnaprasad, and J. Hendler, "Languages, Behaviors, Hybrid Architectures, and Motion Control," in *Math. Control Theory*, J. Baillieul and J. Willems, Editors, Springer-Verlag, pp. 199-226, 1998.
- D. Hristu and S. Andersson, "Directed Graphs and Motion Description Languages for Robot Navigation", IEEE International Conference on Automation and Robotics, 2002.